

DESCRIPTION : ELECTROMAGNETIC HORN – LOW

HK-9/L

PN. 7311022

Main specifications and performances

Nominal voltage	12	Vdc
Voltage range	11.5-13.8	Vdc
Current consumption	3	A
Sound pressure level	110 (2m)	dB(A)
Frequency 'L'	340	Hz
Operating temperature	-30°C to +80	°C
Storage temperature	-30°C to +80	°C
Corrosion resistance	> 480 (salt spray test)	Hours
Operating relative humidity	30 to 80	%
Durability (1 sec ON, 4 sec OFF)	>50 000	Cycles
Continuous blowing	> 3	min
Electrical insulation	1000	Vdc
Vibration (30 min, 3 axis)	1	g
Weight (each)	270	g
Main Materials	Steel-Aluminum	
Main applications	Cars, Trucks, Motorcycles, Special Vehicles	

Dimensions (mm)

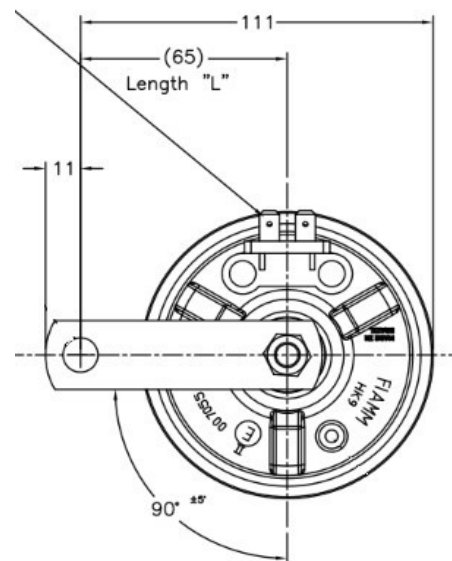

Available Electrical Connection

Double Pole Terminal 6,3x0,8 mm

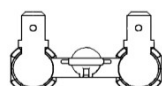

Other specifications

Mechanical connection: flat and rigid surface facing the bracket edge

Horn's Protection: choose an installation area protected from direct water and mud splash

Packaging: Color box 150 x 90 x h82 mm

Master carton: 12 pieces

Conformity to Standards of

PRODUCT C E E 70/388
R. 28 ECE/ONU
CEE 95/54

MANUFACTURING ISO/TS 16949
SO 9001
SO 14001
QS 9000

Part Number 7311022

